

Schematic:

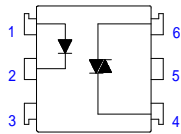

For dimensions and pin-outs, see the last page of this document.

Features:

1. Compact dual-in-line package.
2. 250V peak blocking voltage.
3. 30mA max trigger current
3. Isolation voltage between input and output (Viso:5300Vrms).

Ordering:

Suffix to Standard Part Number

- V = VDE Compliant
- G = 10mm Lead Spread
- S = Surface Mount Lead-form
- T = Tape & Reel

Equivalents:

This part equals/exceeds all specifications of:

OPTO631

Absolute Maximum Ratings:

Parameter		Symbol	Rating	Unit
Input	Forward current	IF	50	mA
	Peak forward current	IFM	1	A
	Reverse voltage	VR	6	V
	Power dissipation	PD	70	mW
Output	Off-State Output Terminal voltage	VDRM	250	VPEAK
	On-State R.M.S. Current	IT(RMS)	100	mA
	Peak Repetitive Surget Current (PW=10ms.DC 10%)	ITSM	1	A
	Power dissipation	Pd	300	mW
Total power dissipation		Ptot	330	mW
Isolation voltage 1 minute		Viso	5300	Vrms
Operating temperature		Topr	-40 to +80	°C
Storage temperature		Tstg	-50 to +125	°C
Soldering temperature 10 second		Tsol	260	°C

Electrical Characteristics:

Parameter		Symbol	Conditions	MIN.	TYP.	MAX.	Unit
Input	Forward voltage	VF	IF=10mA	-	1.2	1.4	V
	Peak forward voltage	VFM	IFM=0.5A	-	-	3.5	V
	Reverse current	IR	VR=4V	-	-	10	uA
Output	Peak Blocking Current	IDRM	VDRM=400V	-	-	100	nA
	ON-State Voltage	VTM	ITM=100mA	-	1.6	3	V
Transfer characteristics	Holding Current	IH		-	0.1	-	mA
	Critical rate of rise of OFF-state voltage	dV/dt	VDRM=(1/√2)*Rated	600	-	-	V/uS
	Isolation resistance	Riso	DC500V	5x10 ¹⁰	10 ¹¹	-	ohm
	Minimum trigger current	IFT	Main Terminal Voltage=3V	-	-	30	mA
	Turn-on time	Ton	VD=6V,RL=100ohm,IF=20mA	-	-	100	uS

Fig.1 Forward Current vs. Ambient Temperature

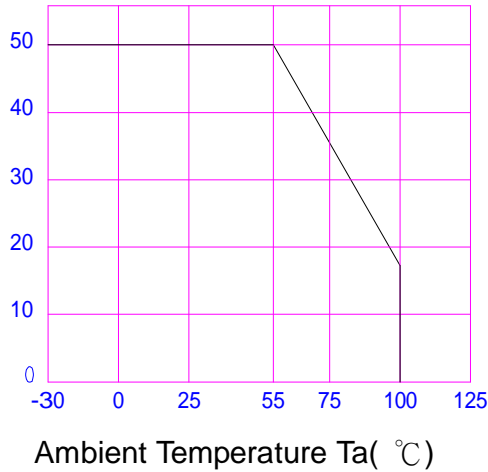

Fig.2 Diode Power Dissipation vs. Ambient Temperature

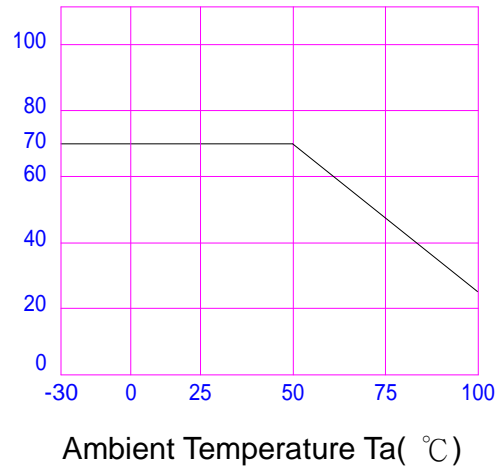

Fig.3 On-State R.M.S. Current vs. Ambient Temperature

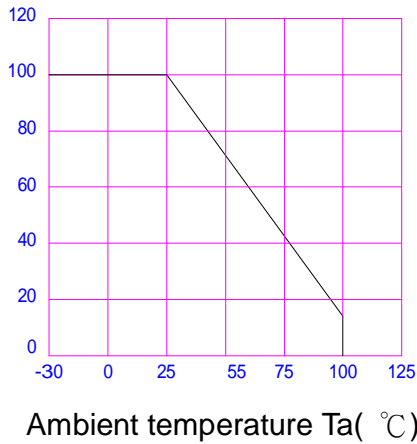

Fig.4 Total Power Dissipation vs. Ambient Temperature

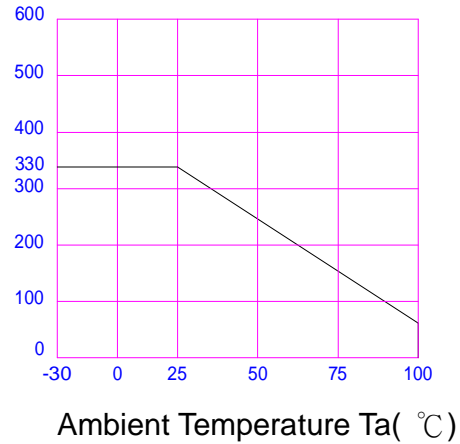

Fig.5 Peak Forward Current vs. Duty Ratio

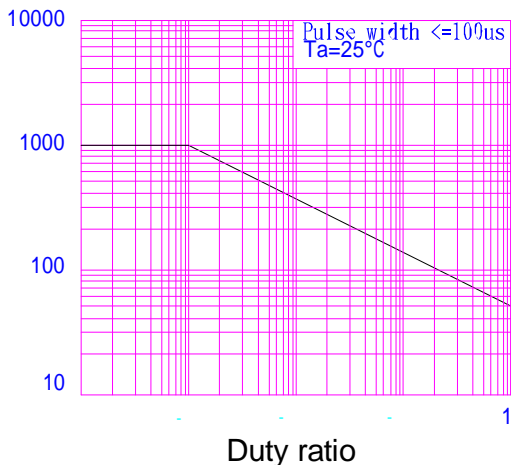

Fig.6 Forward Current vs. Forward Voltage

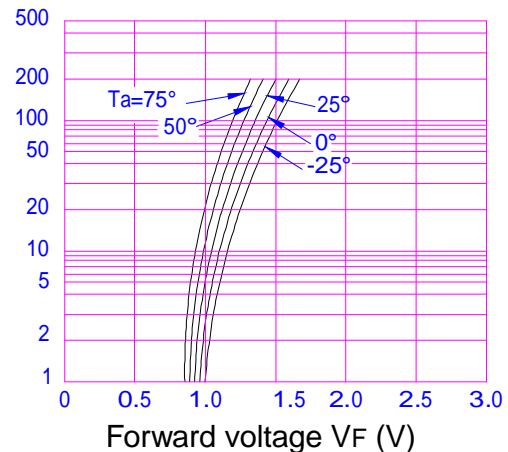
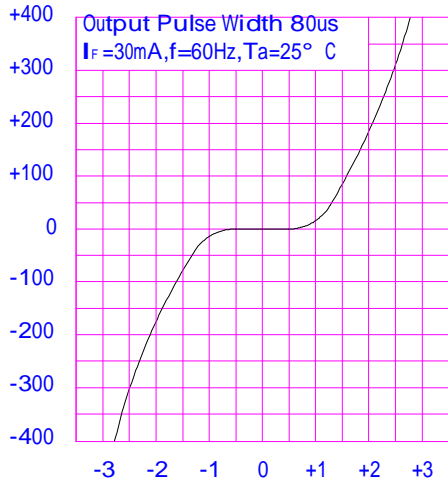
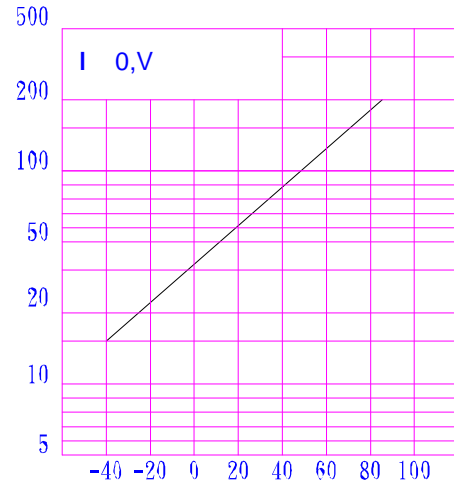

Fig.7 On-State Characteristics



On-State Voltage(V)

Fig.8 Leakage with LED off vs. Ambient Temperature



Ambient Temperature T_a ($^\circ\text{C}$)

Fig.9 Trigger Current vs. Ambient Temperature

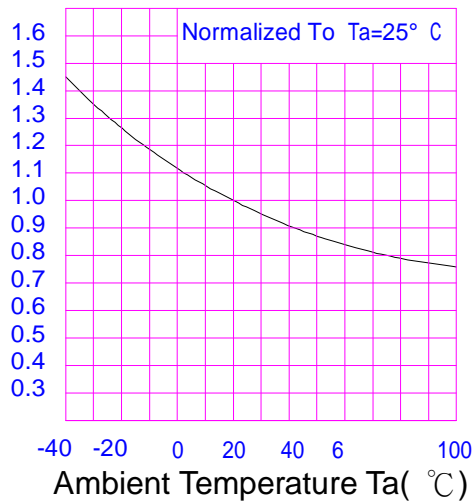

Ambient Temperature T_a ($^\circ\text{C}$)

Fig.4 : 6-pin DIP type

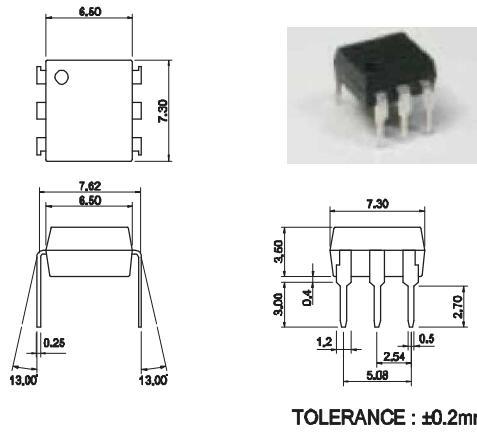

Fig.5 : 6-pin SMD type

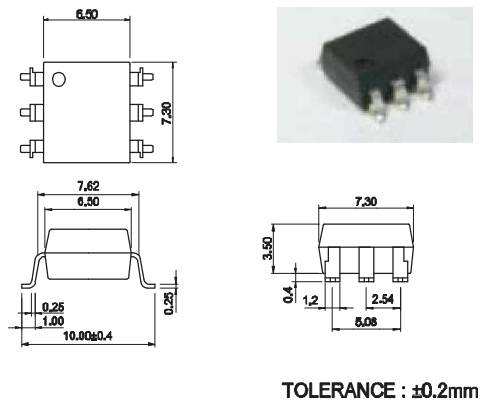

Fig.6 : 6-pin G type

