

Schematic:

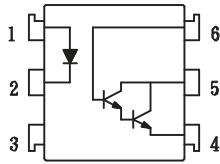

For dimensions and pin-outs, see the last page of this document.

Features:

1. High current transfer ratio
(CTR:MIN.500% at $I_F=10\text{mA}$, $V_{CE}=10\text{V}$)
2. High isolation voltage between input and output
(Viso:5300Vrms).
3. Compact dual-in-line package.

Ordering:

Suffix to Standard Part Number

- V = VDE Approved
- G = 10mm Lead Spread
- S = Surface Mount Lead-form
- T = Tape & Reel

OPTO621

Superior OPTO Part Number:

Absolute Maximum Ratings:

($T_a=25^\circ\text{C}$)

Parameter		Symbol	Rating	Unit
Input	Forward current	I_F	80	mA
	Peak forward current	I_{FM}	1	A
	Reverse voltage	V_R	6	V
	Power dissipation	P_D	70	mW
Output	Collector-emitter voltage	V_{CEO}	55	V
	Collector-base voltage	V_{CBO}	30	V
	Emitter-base voltage	V_{EBO}	6	V
	Collector current	I_C	150	mA
	Collector power dissipation	P_C	200	mW
Total power dissipation		P_{tot}	200	mW
Isolation voltage 1 minute		Viso	5300	Vrms
Operating temperature		T_{opr}	-55 to +100	$^\circ\text{C}$
Storage temperature		T_{stg}	-55 to +125	$^\circ\text{C}$
Soldering temperature 10 second		T_{sol}	260	$^\circ\text{C}$

Electrical Characteristics:

($T_a=25^\circ\text{C}$)

Parameter		Symbol	Conditions	MIN.	TYP.	MAX.	Unit
Input	Forward voltage	V_F	$I_F=10\text{mA}$	—	1.2	1.4	V
	Peak forward voltage	V_{FM}	$I_{FM}=0.5\text{A}$	—	—	3.5	V
	Reverse current	I_R	$V_R=4\text{V}$	—	—	10	μA
	Terminal capacitance	C_t	$V=0$, $f=1\text{kHz}$	—	30	—	pF
Output	Collector dark current	I_{CEO}	$V_{CE}=10\text{V}$, $I_F=0$	—	—	0.1	μA
Transfer characteristics	Current transfer ratio	CTR	$I_F=10\text{mA}$, $V_{CE}=10\text{V}$	500	—	—	%
	Collector-emitter saturation voltage	$V_{CE(sat)}$	$I_F=8\text{mA}$, $I_C=2\text{mA}$	—	—	1.0	V
	Isolation resistance	Riso	DC500V	5×10^{10}	—	—	ohm
	Floating capacitance	C_f	$V=0$, $f=1\text{MHz}$	—	0.6	1.0	pF
	Cut-off frequency	f_c	$V_{CC}=5\text{V}$, $I_C=2\text{mA}$, $R_L=100\text{ohm}$	—	7	—	kHz
	Response time (Rise)	t_r	$V_{CE}=10\text{V}$, $I_C=50\text{mA}$, $R_L=100\text{ohm}$	—	5	40	μs
	Response time (Fall)	t_f		—	60	100	μs

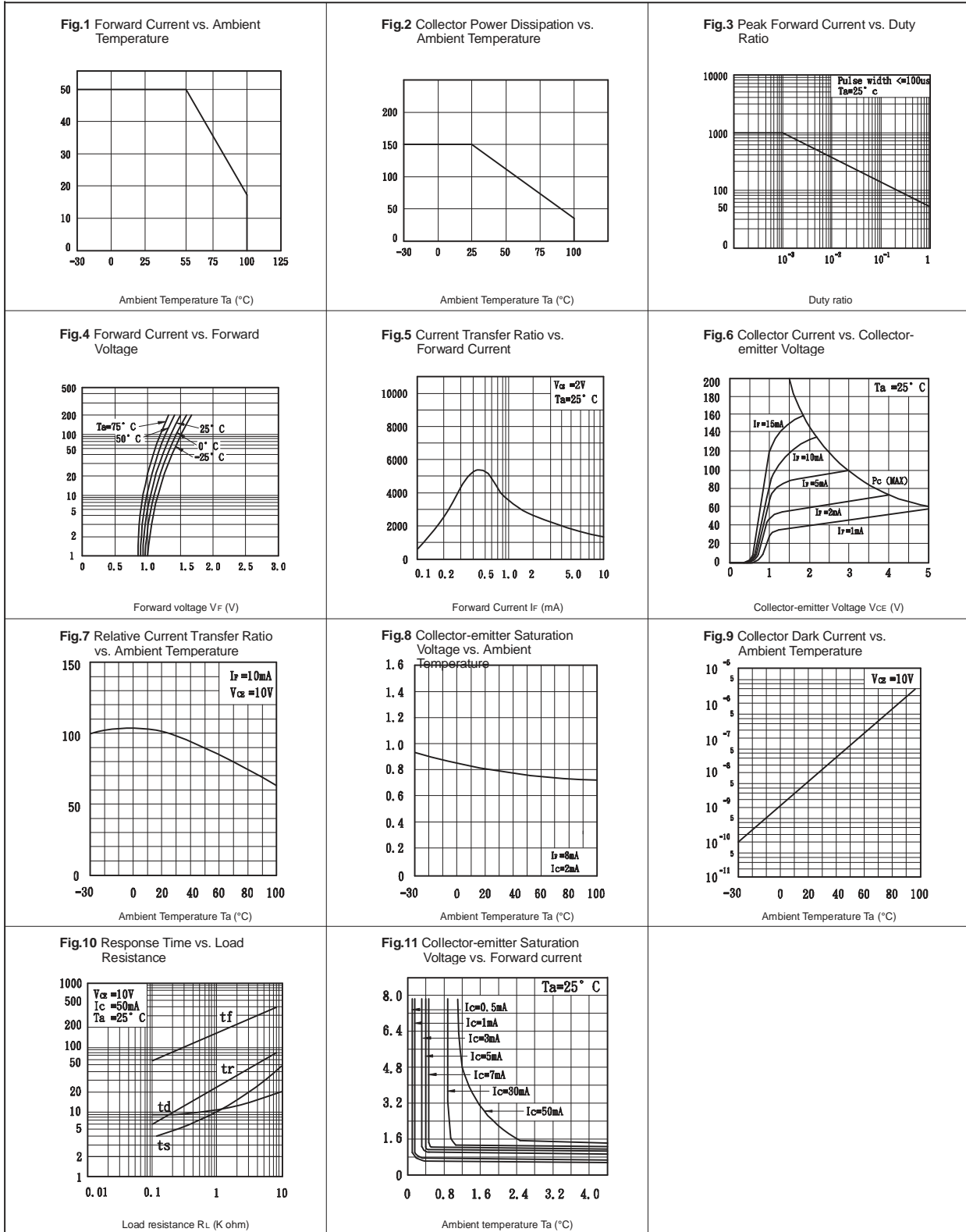

Fig.4 : 6-pin DIP type

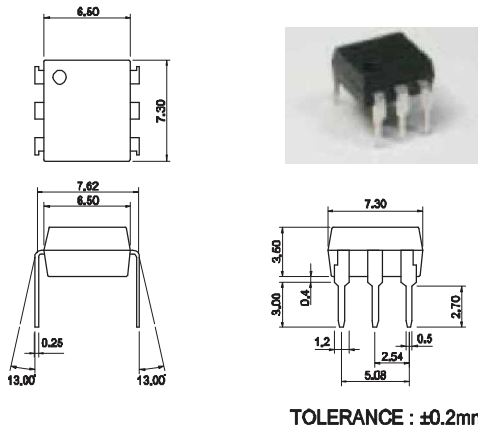

Fig.5 : 6-pin SMD type

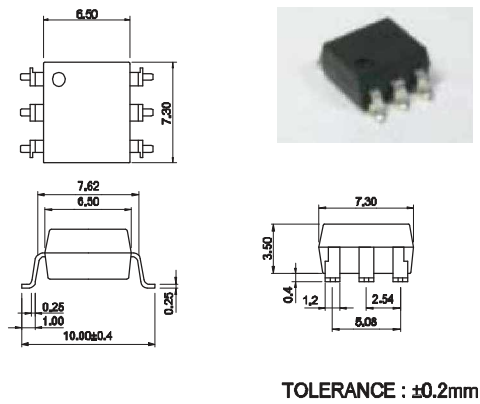

Fig.6 : 6-pin G type

