

Schematic:

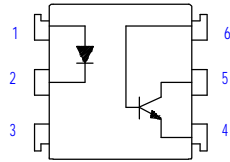

For dimensions and pin-outs, see the last page of this document.

Features:

1. Current transfer ratio
(CTR min 20% at $I_F=10mA$ $V_{ce}=10V$)
2. High isolation voltage between input and output
($V_{iso} = 5300V_{rms}, 7500V_{pk}$).

Ordering:

Suffix to Standard Part Number

- V = VDE Compliant
- G = 10mm Lead Spread
- S = Surface Mount Lead-form
- T = Tape & Reel

Superior OPTO Part Number:

OPTO611

Absolute Maximum Ratings:

	Parameter	Symbol	Rating	Unit
Input	Peak forward current	I_{FM}	1	A
	Reverse voltage	V_R	6	V
	Power dissipation	P_D	70	mW
	Collector-emitter voltage	V_{CEO}	30	V
Output	Emitter-collector voltage	V_{ECO}	6	V
	Collector-base voltage	V_{CBO}	60	V
	Emitter-base voltage	V_{EBO}	6	V
	Collector current	I_C	50	mA
	Collector power dissipation	P_C	150	mW
	Total power dissipation	P_{tot}	200	mW
Isolation voltage 1 minute		V_{iso}	5300	V_{rms}
		V_{iso}	7500	V_{pk}
Operating temperature		T_{opr}	-55 to +100	$^{\circ}C$
Storage temperature		T_{stg}	-55 to +125	$^{\circ}C$
Soldering Temperature 10 seconds		T_{sol}	260	$^{\circ}C$

Electrical Characteristics:

	Parameter	Symbol	Conditions	MIN.	TYP.	MAX.	Unit
Input	Forward voltage	V_F	$I_F=20mA$	-	1.2	1.4	V
	Peak forward voltage	V_{FM}	$I_{FM}=0.5A$	-	-	3.5	V
	Reverse current	I_R	$V_R=4V$	-	-	10	μA
	Terminal capacitance	C_t	$V=0, f=1kHz$	-	30	-	pF
Output	Collector dark current	I_{CEO}	$V_{CE}=20V$	-	-	0.1	μA
Transfer characteristics	Current transfer ratio	CTR	$I_F=10mA, V_{CE}=5V$	20	-	-	%
	Collector-emitter saturation voltage	$V_{CE(sat)}$	$I_F=50mA, I_C=2mA$	-	-	0.5	V
	Isolation resistance	R_{iso}	DC500V	5×10^{10}	10^{11}	-	ohm
	Floating capacitance	C_f	$V=0, f=1MHz$	-	0.6	1.0	Pf
	Cut-off frequency	f_c	$V_{cc}=5V, I_C=2mA, R_L=100ohm$	-	80	-	kHz
	Response time (Rise)	t_r	$V_{ce}=2V, I_C=2mA, R_L=100ohm$	-	5	20	us
Response time (Fall)	t_f		-	4	20	us	

Fig. 1 Current Transfer Ratio
 Vs. Forward Current

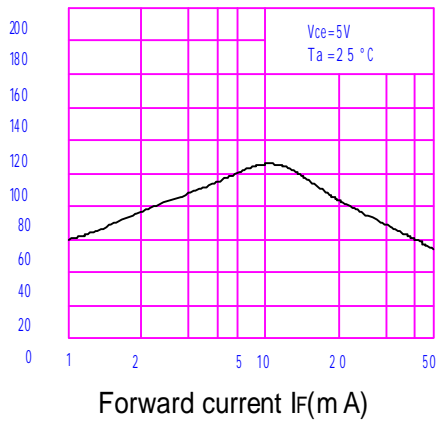

Fig.2 Collector Power Dissipation
 vs. Ambient Temperature

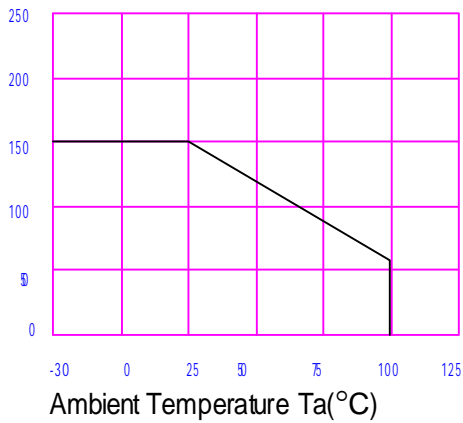

Fig.3 Collector Dark Current vs.
 Ambient Temperature

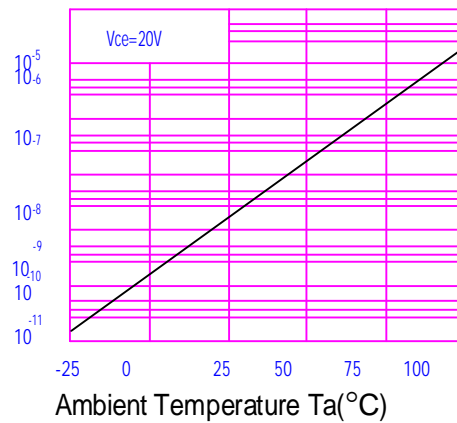

Fig.4 Forward Current vs.
 Ambient Temperature

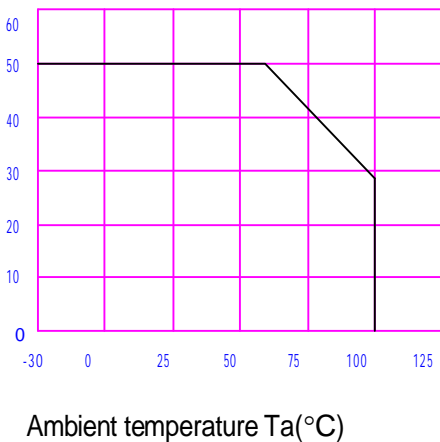

Fig.5 Forward Current vs.
 Forward Voltage

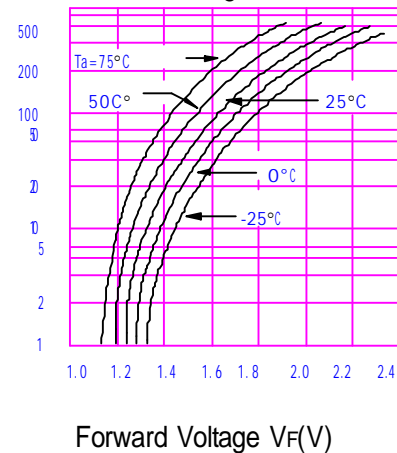

Fig.6 Collector Current vs.

Collector-emitter Voltage

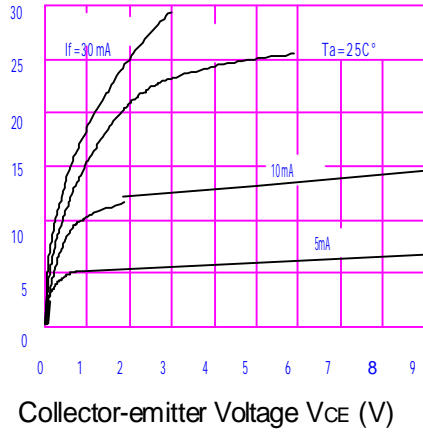

Fig.7 Relative Current Transfer Ratio

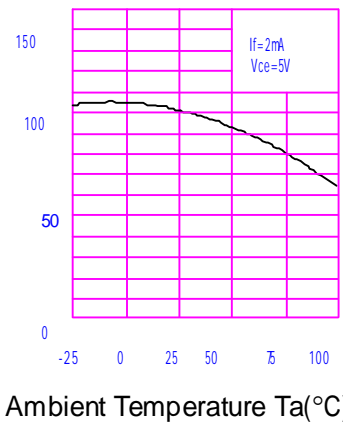

Fig.8 Collector-emitter Saturation Voltage vs. Ambient Temperature

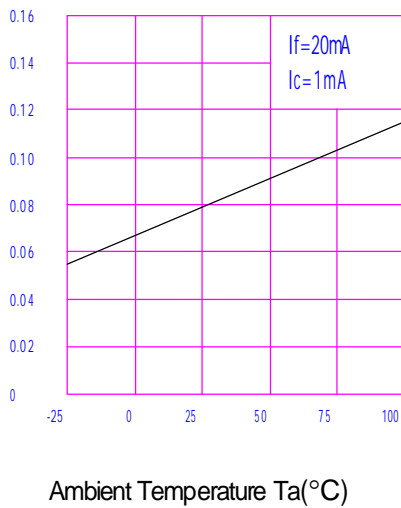

Fig.9 Collector-emitter Saturation Voltage vs. Forward Current

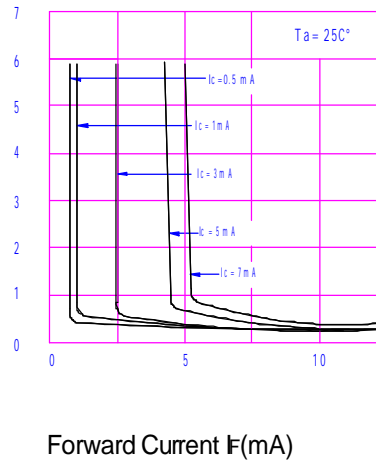

Fig.10 Response Time vs. Load Resistance

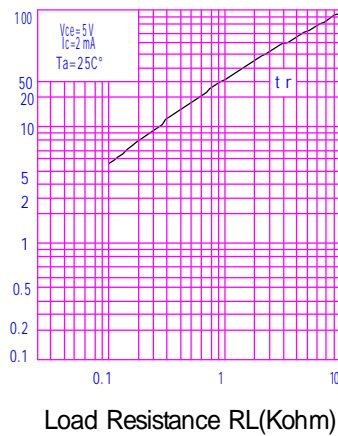
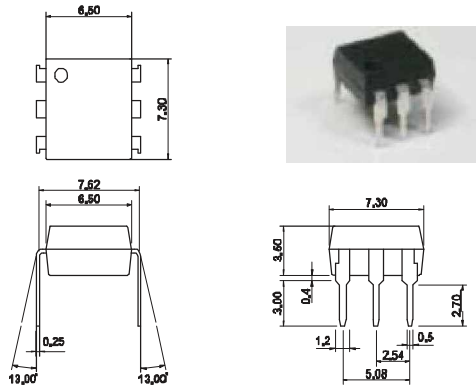

Fig.11 Response Time vs. Load Resistance

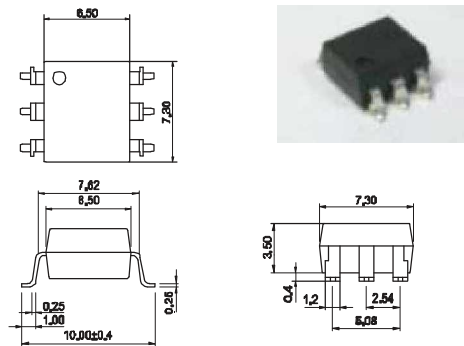

Fig.4 : 6-pln DIP type



TOLERANCE : $\pm 0.2\text{mm}$

Fig.5 : 6-pln SMD type



TOLERANCE : $\pm 0.2\text{mm}$

Fig.6 : 6-pln G type

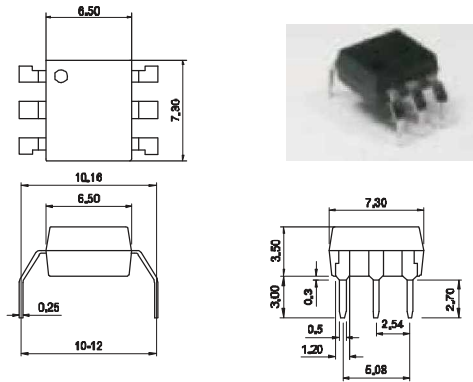

TOLERANCE : $\pm 0.2\text{mm}$

6-pin SMD Carrier Tape & Reel

Unit:mm

Tape

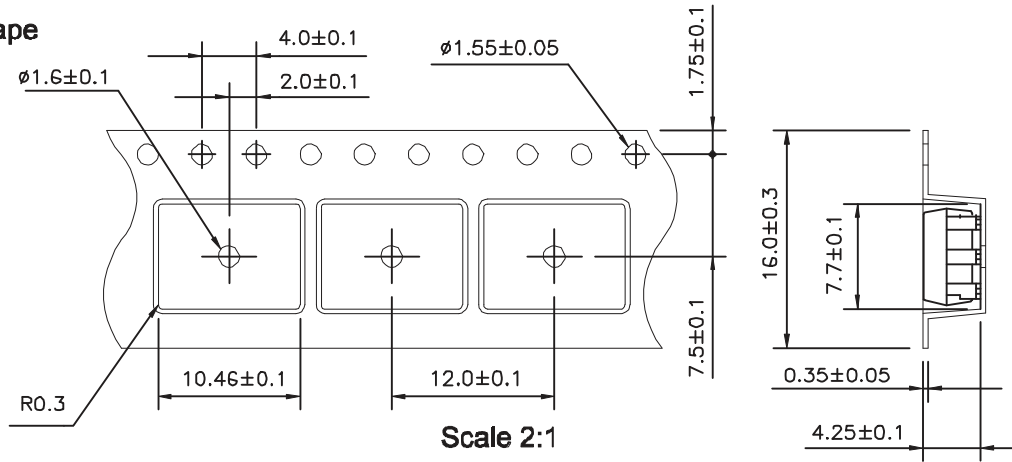

Scale 2:1

Material : PS

Direction

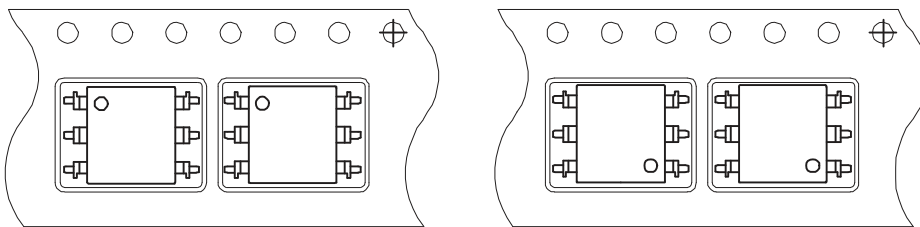

TL

TR

Reel

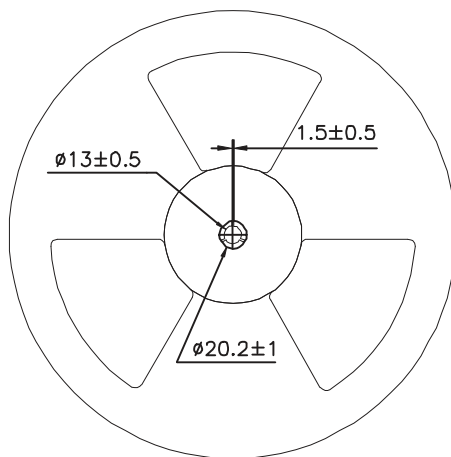

Scale 1:5

Material : PVC

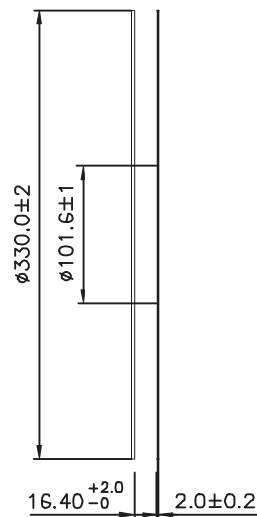

Packing:1000pcs/reel